

# TRICK

Performance Products

"It's Only Worth Using If It's TRICK!"



www.trickperformanceproducts.com

# Black Series

Display Controllers



## **V - Black Series** **NITROUS OXIDE VOLUME AND PRESSURE** **DISPLAY CONTROLLER**

### **INSTALLATION AND USER MANUAL**



Trick Performance Products  
PO Box 4395 Wichita Falls, TX 76308  
Tel: 940-781-5204  
www.trickperformanceproducts.com

"It's only worth using if it's Trick"

# Table of Contents

Page

<b>WHAT THE GAUGE CAN DO .....</b>	<b>3</b>
<i>Basic Features: .....</i>	<i>3</i>
<i>Advanced Programmable Features: .....</i>	<i>3</i>
<b>Programming V - BLACK SERIES gauge. ....</b>	<b>4</b>
<i>STEP 1. Entering Main Programming Screen.....</i>	<i>4</i>
<i>STEP 2. Configure set up.....</i>	<i>4</i>
<i>STEP 3. Configure set up--Stage Setups. ....</i>	<i>5</i>
<i>STEP 4. Configure set up--Bottle Level. ....</i>	<i>6</i>
<i>STEP 5. Configure set up--Bottle Pressure.....</i>	<i>7</i>
<i>STEP 6. Configure set up--Sensor #2. ....</i>	<i>8</i>
<i>STEP 7. Configure set up--Target Pressure. ....</i>	<i>10</i>
<i>STEP 8. Configure set up--Safety Cutouts. ....</i>	<i>10</i>
<b>Calibrating Bottle Capacity .....</b>	<b>11</b>
<b>Programming Tips &amp; Warnings!!!.....</b>	<b>12</b>
<b>Specifications.....</b>	<b>12</b>
<b>Warranty .....</b>	<b>13</b>
<b>Wiring Diagrams.....</b>	<b>14</b>

**TO AVOID DAMAGING THE DISPLAY, NEVER PUSH ON THE SCREEN.**

The Trick Performance Products **V - BLACK SERIES** gauge will control many aspects of your nitrous oxide system. This device is the world's first all-in-one full color controller with integrated display. No need for a laptop computer or additional boxes; it's all in the 2-1/16<sup>th</sup> inch gauge. The V - BLACK SERIES combines microprocessor controls & with a real world color user interface. The **V** gauge (pn-TPP-00029) + (pn-TPP-00024) will display how much nitrous you have remaining in the bottle, your bottle pressure, and control a heater to maintain your target bottle pressure. You will be able to program the gauge in seconds after reading the instructions. Take the time and read all the instructions before beginning your installation. Failure or damage may occur if all the wiring and programming are not done properly.

## **WHAT THE GAUGE CAN DO**

The Trick **V** gauge can be used for many items that relate to the operation of your nitrous system.

### ***Basic Features:***

- Display current nitrous oxide volume
- Display bottle pressure, and 1 other pressure or Air/fuel ratio.
- Control bottle heater based on bottle pressure

### ***BUT IT ALSO CAN BE A COLOR:***

- Graphical display of all configured options
- AIR/FUEL Gauge that supports all O2 widebands with a programmable analog output
- Nitrous Pressure Gauge with programmable safety set points.
- Boost Gauge with programmable safety set points.
- Fuel Pressure Gauge with programmable safety set points.
- Oil Pressure Gauge with programmable safety set points.
- Automatic Bottle Heater Control with safety shut-off
- Water temperature

### ***Advanced Programmable Features:***

- Lean and Rich Cut-Off
- Pressure Hi or Lo Cut-off
- User defined color ranges for each configured option

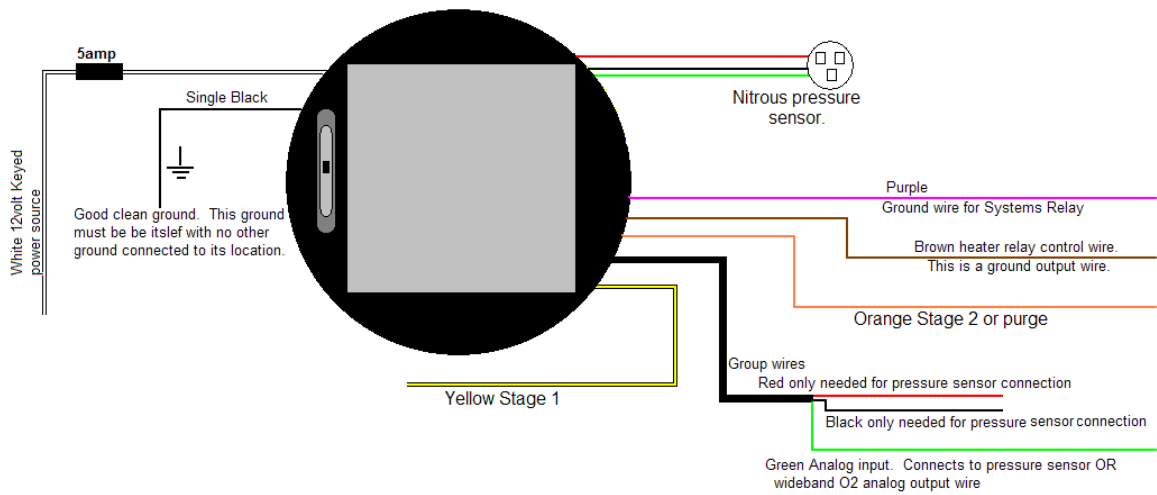

**DO NOT PUSH ON THE SCREEN WHILE PLUGGING IN THE HARNESS AS YOU WILL DAMAGE THE UNIT.**

## Programming V - BLACK SERIES gauge.

### STEP 1. Entering Main Programming Screen

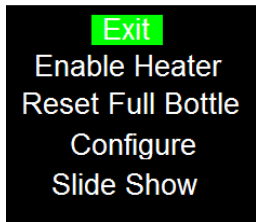

After properly wiring your gauge turn the power on. You will see a couple of splash screens come up. Now push the control button in. You will see the Main Programming Screen. Toggle down one space.

This is your Enable or Disable heater control. Push the control button in to toggle the heater setting, and this will automatically return you to the top of the page. Once you have set your heater mode, toggle down 3 spaces to the Configure button.

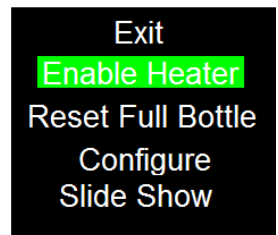

**Note:** We have skipped the reset full bottle because it is discussed later in the install.

### STEP 2. Configure set up.

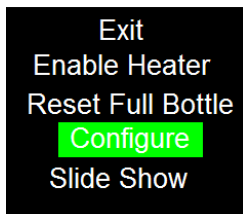

Push the control button in. You are now at the Exit & Save Screen.

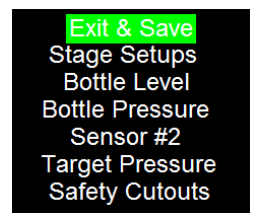

### STEP 3. Configure set up--Stage Setups.

Exit & Save  
Stage Setups  
Bottle Level  
Bottle Pressure  
Sensor #2  
Target Pressure  
Safety Cutouts

This is where you will set up the Horsepower levels of your stages and tell the controller how the solenoids are turned on/off.

SCROLL DOWN:

This is your Stage 1 Horsepower level. Push the control button (numbers will change to blue) and adjust up or down until it matches your HP jetting. Use the HP rating your nitrous company publishes. Once you have your HP level programmed, push the control button in.

Exit  
S1 HP: 50  
S1 Pol: +++  
S2 HP: 100  
S2 Pol: ---

SCROLL DOWN:

Exit  
S1 HP: 50  
S1 Pol: +++  
S2 HP: 100  
S2 Pol: ---

This is your Stage 1 Polarity. Your choices are +++ (positive) or --- (negative). You can connect your Stage sensing wires to the Positive or Negative side of your nitrous solenoids. Pushing the control button in will toggle between these two settings.

**Note:** +++ is used for systems where the power is switched on/off to fire the solenoids. --- is used when the negative side is switched to fire the solenoids. --- is used by most progressive controllers.

SCROLL DOWN:

This is your Stage 2 Horsepower level. Push the control button (numbers will change to blue) and adjust up or down until it matches your HP jetting. Use the HP rating your nitrous company publishes. Once you have your HP level programmed, push the control button in. If no 2<sup>nd</sup> stage is being used in your application you can attach this wire to your purge valve. Most purge valves are similar to a 150hp level.

Exit  
S1 HP: 50  
S1 Pol: +++  
S2 HP: 100  
S2 Pol: ---

SCROLL DOWN:

Exit  
S1 HP: 50  
S1 Pol: +++  
S2 HP: 100  
S2 Pol: ---

This is your Stage 2 Polarity. Your choices are +++ (positive) or --- (negative). You can connect your Stage sensing wires to the Positive or Negative side of your nitrous solenoids. Pushing the control button in will toggle between these two settings.

Note: +++ is used for systems where the power is switched on/off to fire the solenoids. --- is used when the negative side is switched to fire the solenoids. --- is used by most progressive controllers.

Once you have programmed the POL setting, then Scroll Down to the EXIT and push the control button in. This will return you to Exit & Save Screen. You are now on Bottle Level. Push your control button in to enter this set up.

Exit & Save  
Stage Setups  
Bottle Level  
Bottle Pressure  
Sensor #2  
Target Pressure  
Safety Cutouts

## STEP 4. Configure set up--Bottle Level.



This is your Bottle Level Screen. Because EMPTY is subjective, different users will have different levels at which they consider the bottle to be empty. The gauge is programmed with a default empty level and may not accurately display the true level in your tank until you have calibrated it. This will be discussed at the end of the programming section.

SCROLL DOWN:

You have 8 choices of colors for your bottle, BLUE, PURPLE, BLACK, RED, ORANGE, YELLOW, GREEN, and SILVER. Push your control button and scroll up or down to find the bottle color that fits your needs. Once you have programmed the Bottle Color push the control button in to save it.



SCROLL DOWN:



This is the Green to Yellow change point which is a visual aid on the main viewing screen. To change the %, push your control button in (the text will change to blue) and toggle up or down to change the value. If you hold the control button in the up or down position, the numbers will scroll. Once you have the % programmed for your needs, push the control button in to save it.

SCROLL DOWN:

This is the Yellow to Red change point which is a visual aid on the main viewing screen. To change the %, push your control button in (the text will change to blue) and toggle up or down to change the value. If you hold the control button in the up or down position the numbers will scroll. Once you have the % programmed for your needs, push control button in to save it. This low-side number is used to visually let you know you are getting close to **YOUR** empty level.



SCROLL DOWN: to the EXIT and push the control button in. This will return you to the Exit & Save Screen. You are now on Bottle Pressure.

## STEP 5. Configure set up--Bottle Pressure.

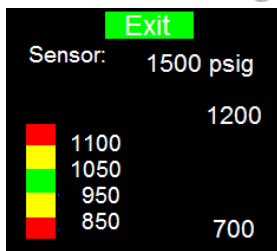

This is your Bottle pressure set up screen. It is used to set the pressure sensor type, and customize the color shift points for the Nitrous pressure data on the Main Viewing screen.

SCROLL DOWN:

Push your control button in and match your sensor rating. Your choices are 1500, 1600, and none. If you choose none you will have NO nitrous pressure reading on the Main viewing screen, and lose some accuracy on the volume used. Once you have the sensor type programmed, push the control button in to save it.

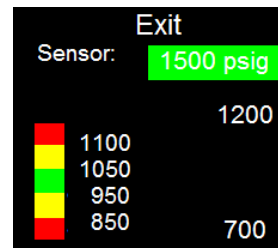

SCROLL DOWN:

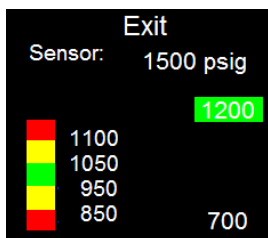

This is your hi-side scaling which sets the upper limit of the Main Viewing screen. The closer this number is to your actual hi-side the more accurate your scaling resolution is. Normally 150-200 psi higher than Yellow to Red transition is a good place to be. Push the control button in (text will turn blue) and make adjustments up or down to fit your needs. Once done, push the control button in to save it.

SCROLL DOWN:

This is the Yellow to Red change which is a visual aid for the main viewing screen. The nitrous pressure display on the Main Viewing screen will change from yellow to red at this point. Push your control button in (the text will change to blue). Make adjustments up or down to fit your needs. IF you hold the control button in the up or down position the numbers will scroll. Once you have the number programmed for your needs, push the control button in to save it.

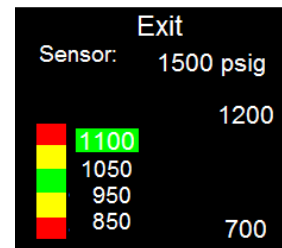

SCROLL DOWN:

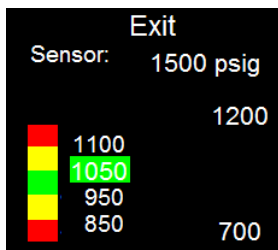

This is the Green to Yellow change which is a visual aid for the main viewing screen. The nitrous pressure display on the Main Viewing screen will change from green to yellow at this point. Push your control button in (the text will change to blue). Make adjustments up or down to fit your needs. If you hold the control button in the up or down position the numbers will scroll. Once you have the number programmed for your needs, push the control button in to save it.

SCROLL DOWN:

This is the Yellow to Green change which is a visual aid for the main viewing screen. The nitrous pressure display on the Main Viewing screen will change from yellow to green at this point. Push your control button in (the text will change to blue). Make adjustments up or down to fit your needs. If you hold the control button in the up or down position the numbers will scroll. Once you have the number programmed for your needs, push the control button in to save it.

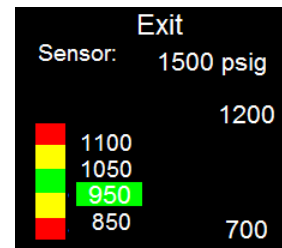

SCROLL DOWN:

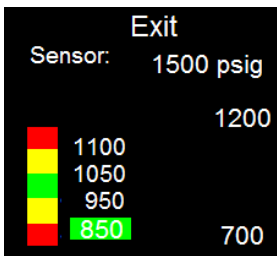

This is the Red to Yellow change which is a visual aid for the main viewing screen. The nitrous pressure display on the Main Viewing screen will change from red to yellow at this point. Push your control button in (the text will change to blue). Make adjustments up or down to fit your needs. If you hold the control button in the up or down position the numbers will scroll. Once you have the number programmed for your needs, push the control button in to save it.

SCROLL DOWN:

This is your low-side scaling and sets the lower limit of the Main Viewing screen. The closer this number is to your actual low-side the more accurate your scaling resolution is. Normally 150-200 psi lower than Red to Yellow transition is a good place to be. Push the control button in (text will turn blue) and make adjustments up or down to fit your needs. Once done, push the control button in to save it.

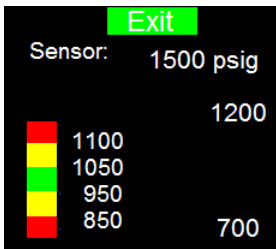
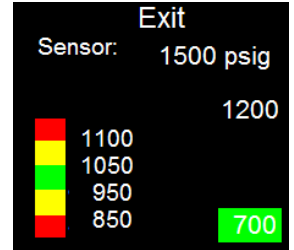

Scroll to the Exit and push the Control button in.

## STEP 6. Configure set up--Sensor #2.

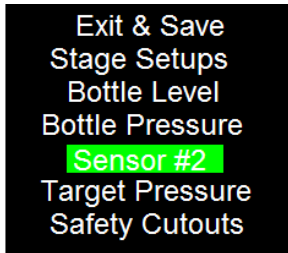

Push your control button in.

This is your Sensor #2 setup screen. The #2 sensor can be air/fuel, AFR, Nitrous, Coolant, MAP, Water, Oil, Fuel, and Other. This is also what your Safety Cut-outs will use for its labelling and the labelling on the Main Viewing Screen.

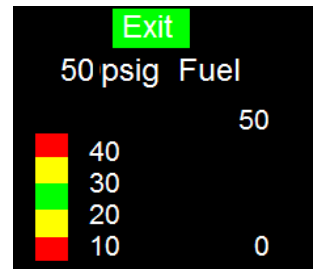

SCROLL DOWN:

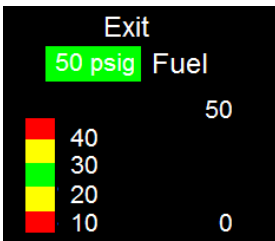

Push the control button in (the text will turn blue) and adjust up or down to find the **sensor** that fits your needs. Your choices are, None, 15psig, 50psig, 100psig, 200psig, 1500psig, 1600psig, Air/Fuel. For Air/Fuel you attach the analog output wire from your wideband. The analog signal of the wideband must be a linear 5v ramp where **0.5v =10 AFR and 4.5v=20AFR**. Once you have selected the sensor for your needs, push the control button in.

SCROLL DOWN:

Push the control button in (the text will turn blue) and adjust up or down to find the Label for the sensor you have chosen. Your choices are AFR, Air/Fuel, Other, Fuel, Oil, Air, MAP, Water, Coolant, Nitrous. This is the label you will see on the Main Viewing Screen for your #2 Sensor. Once you have selected the label, push the control button in to save it.

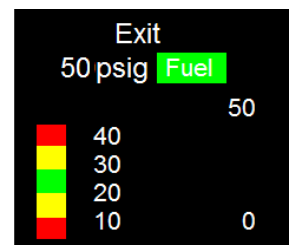

SCROLL DOWN:

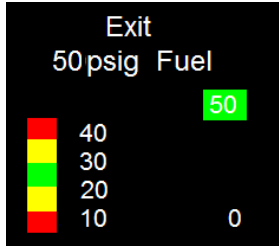

This is your hi-side scaling which sets the upper limit of the Main Viewing screen. The closer this number is to your actual hi-side the more accurate your scaling resolution is. Push the control button in (text will turn blue) and make adjustments up or down to fit your needs. Once done, push the control button in to save it.

SCROLL DOWN:

This is the Yellow to Red change. This is a visual aid for the main viewing screen. The sensor #2 display on the Main Viewing screen will change from yellow to red at this point. Push your control button in (the text will change to blue). Make adjustments up or down to fit your needs. If you hold the control button in the up or down position, the numbers will scroll. Once you have the number programmed for your needs, push control button in to save it.

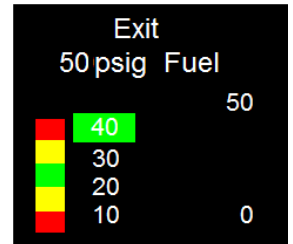

SCROLL DOWN:

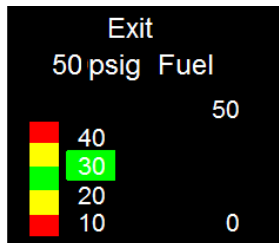

This is the Green to Yellow change which is a visual aid for the main viewing screen. The sensor #2 display on the Main Viewing screen will change from green to yellow at this point. Push your control button in (the text will change to blue). Make adjustments up or down to fit your needs. IF you hold the control button in the up or down position the numbers will scroll. Once you have the number programmed for your needs, push the control button in to save it.

SCROLL DOWN:

This is the Yellow to Green change which is a visual aid for the main viewing screen. The sensor #2 display on the Main Viewing screen will change from yellow to green at this point. Push your control button in (the text will change to blue). Make adjustments up or down to fit your needs. IF you hold the control button in the up or down position the numbers will scroll. Once you have the number programmed for your needs, push the control button in to save it.

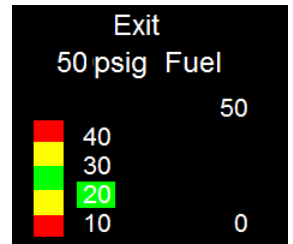

SCROLL DOWN:

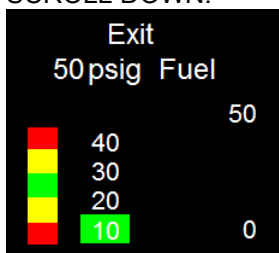

This is the Red to Yellow change which is a visual aid for the main viewing screen. The sensor #2 display on the Main Viewing screen will change from red to yellow at this point. Push your control button in (the text will change to blue). Make adjustments up or down to fit your needs. IF you hold the control button in the up or down position the numbers will scroll. Once you have the number programmed for your needs, push the control button in to save it.

SCROLL DOWN:

This is your low-side scaling which sets the lower limit of the Main Viewing screen. The closer this number is to your actual low-side, the more accurate your scaling resolution is. Push the control button in (text will turn blue) and make adjustments up or down to fit your needs. Once done, push the control the button in to save it.

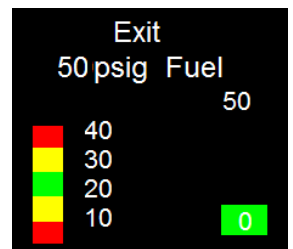

## STEP 7. Configure set up--Target Pressure.

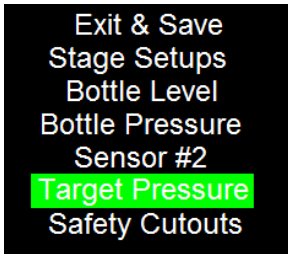

Push your control button in.

This screen allows you to set the target pressure for the bottle heater control. Scroll up or down to set your target pressure. This screen only has one adjustment so you can scroll up or down without pushing the control button in. To save your setting, push the control button in and you will return to the Exit & Save Screen.

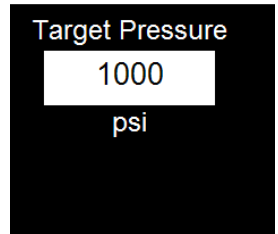

Note: If the bottle pressure is too low or if after 15 minutes there has been no pressure change, the bottle heater will be turned off until you manually enable it again.

## STEP 8. Configure set up--Safety Cutouts.

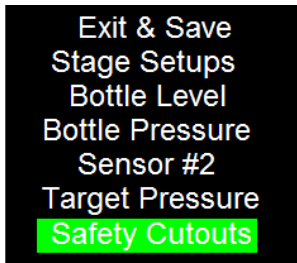

Push the control button in.

This is the Safety Cutoff setup screen where you can program the gauge to cut your nitrous system. (Requires a relay). Because some input types may have signal spikes that can cause a false trigger, each cut-off has a delay time to help filter these. The gauge requires the trigger condition to be present for longer than the set delay time before it will trigger a cut off.

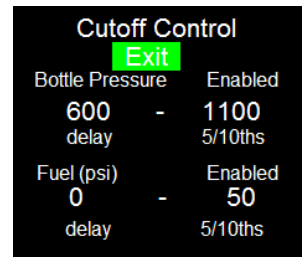

SCROLL DOWN:

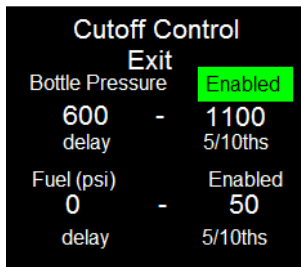

This screen allows you to select which sensor will trigger a cutoff [Enabled]. Disabling a sensor prevents it from triggering the cutoff.

SCROLL DOWN:

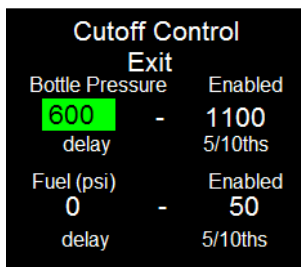

This is your LOW bottle pressure set point. If your bottle pressure drops below this point, your cutoff relay will be activated. Push the control button in (text will change to blue) and make adjustments up or down to fit your needs. Once your low side pressure is set, push the control button in to save it.

SCROLL DOWN:

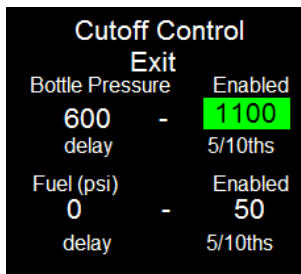

This is your HI bottle pressure set point. If your bottle pressure rises above this point your cutoff relay will be activated. Push the control button in (text will change to blue) and make adjustments up or down to fit your needs. Once your hi side pressure is set, push the control button in to save it.

SCROLL DOWN:

This is the delay for the nitrous pressure. This determines how long the bottle pressure must be above you hi set point or below your low set point before activating the cutoff relay. Push the control button in to adjust this up or down. Once your delay is set, push the control button in again to save it.

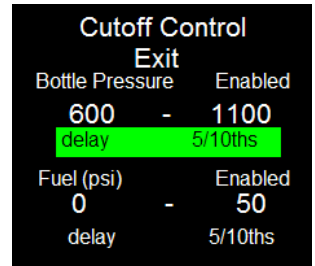

SCROLL DOWN:

This will allow you to set the same settings for sensor #2 as you did for the nitrous bottle pressure. Once you have finished setting your cutoff selections, scroll to the Exit and push the control button in to return to the Exit and Save screen.

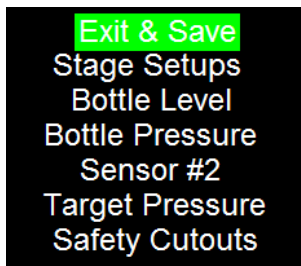

Pushing the control button in at this time will save and return you to the Main Viewing Screen.

## Calibrating Bottle Capacity

**Note: Before calibrating the gauge you must have correctly configured the gauge and have a full tank connected to your system**

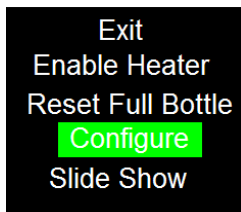

Press the control button and scroll to **Reset Full Bottle**. Press the control button in and the gauge will now be set to full and will return to the main screen. Now use your nitrous system as you would normally.

**Note:** Because EMPTY is subjective, different users will have different levels at which they consider the bottle to be empty. The gauge is programmed with a default empty level and may not accurately display the true level in your tank until you have calibrated it. If the tank shows empty but it is not, continue to use the system as you would have before.

Once you reach the level that you consider your empty level, go to the bottle level configuration screen, select **Set Empty** and press the control button in to save. NOW every time you refill your bottle you must press the control button and scroll to **Reset Full Bottle**. Press the control button in and the gauge will now be set to full, and you will return to the main screen. Now use your nitrous system as you would normally.

REMINDER: every time you put a full bottle into the car, you must tell the gauge you did so.



**Important:** Each time the gauge detects that your solenoids are activated, it begins to track your nitrous usage and will display an hourglass ICON. **DO NOT power off the gauge while the hourglass ICON is present.** Once the gauge detects that no further solenoid activity has occurred, it updates the usage log and turns off the ICON. At this point it is safe to power off the gauge. Failure to do this will impact the accuracy of the gauge.

## Programming Tips & Warnings!!!

Here are some tips for moving around and reprogramming your gauge.

- On the main viewing screen, push the control button up will change your screen to different views. This allows you to watch your sensors as just like it's another gauge. EXP. While tuning N/A you could watch air/fuel as if your **V** gauge was just an air/fuel gauge. (sensor must be programmed and plugged into an Air/Fuel source).
- On the main viewing screen, push the control button down and your gauge will dim. Helpful when driving at night to lessen the brightness of your **V** gauge. Push down again to return to bright.
- You do not have to go through each programming screen just to program 1 screen. You can enter configure mode and can jump to which ever mode you need to adjust. Same goes within a configure mode you can jump to the parameter you want to adjust. When finish just exit out then Exit/Save and you are done.
- Your heaters default mode is disabled. You will always need to enable your heater for it to work and heat your bottle, when you power down your gauge the heater will turn off.
- You may see some coloration though the bar graph areas. This is called banding and is normal and will not hurt the gauge in any way.
- When you have a cutout trip you will see a large RED area around the area that caused the trip. You will need to push the control button in, to reset this feature. This allows you to see what caused the nitrous system to turn off.
- Throughout your programming the term scaling is used. This deals with the bar under your numerical readouts.
- Make sure the ground wire to the **V** gauge is by itself on a good clean area, (meaning no other wires are connected to it or in the general area). Especially hi amp cycling wires like solenoids etc.
- **NEVER PUSH ON THE SCREEN WHEN INSERTING ELECTRICAL SOCKET, DAMAGE TO THE SCREEN WILL HAPPEN.**
- **NEVER CONNECT THE POWER AND GROUND BACKWARDS. THIS WILL FRY YOUR GAUGE.**

## Specifications

Power	10~18 volts dc
Physical Dimensions	2 1/16 <sup>th</sup> inch diameter by 2 1/2 inch deep [fits standard gauge pod or cup]
Display Dimension	1 1/8 <sup>th</sup> by 1 1/8 <sup>th</sup> inches
Relay Control Output Current	1 Amp max.
Sensor Inputs	5-volt max.
Weight	3 ounces [gauge only]

# Warranty

## DISCLAIMER:

Trick Performance Products, LLC may not be held responsible for any damages, how so ever caused, to any persons or equipment during the installation and or operation of this product. Trick Performance Products are meant for OFF-ROAD use only, and make no claims as to this products ability to meet local safety or emissions laws.

## WARRANTY:

Trick Performance Products, LLC (TPP ) warrants the material and workmanship of the equipment, components and parts manufactured by TPP LLC against defects under normal use and service. This warranty shall extend for 90 days from the date of purchase provided that the customer first returns the defective part or component through an authorized dealer, shipping costs prepaid. Prior to returning a product for warranty inspection, the customer must contact TPP's service department with the product serial number to receive a WARRANTY CLAIM NUMBER. Units returned without this number will be delayed or refused.

TPP may at its option, repair or replace without cost for parts and labor, the defective product. This warranty does not cover finishes, normal wear and tear, nor does it cover damage resulting from accident, misuse, dirt, tampering, unreasonable use, service attempted or performed by unauthorized service agencies, ACTS of Devine intervention, failure to provide reasonable maintenance, or that have been modified or used for commercial reasons.

TPP specifically does not warrant equipment, parts or components purchased by TPP or the customer from any third party manufacturers or suppliers. Rather, for and defect equipment, parts and components purchased from third party manufacturers or suppliers, the customer shall have a recourse only to the terms of the warranty of that particular manufacturer or supplier. Any recommendations made by the third party manufacturer or suppliers concerning the use or application of their products are those of the manufacturer or suppliers, and TPP extends no warranty with respect to the results obtained for their use. TPP does not warranty those products in any way beyond the tern of the warranty extended by the manufacturer or supplier.

The warranty provided above, TPP's obligations and liabilities hereafter, and the rights and remedies of the customer are exclusive and is substitution for, and the customer waives all other warranties, guarantees, obligations, liabilities, rights and remedies, expressed or implied, arising by law or otherwise, including ( without limitation ) the implied warranties of merchantability or fitness or purpose, and any obligations or liability or TPP arising from tort, or loss of use, revenue or profit, or the incidental or consequential damage.

Do to the many different ways to wire a nitrous system we cannot show every possible solution. These are just a few of the way the TPAS can be wired and used.

# Wiring Diagrams

illustration +

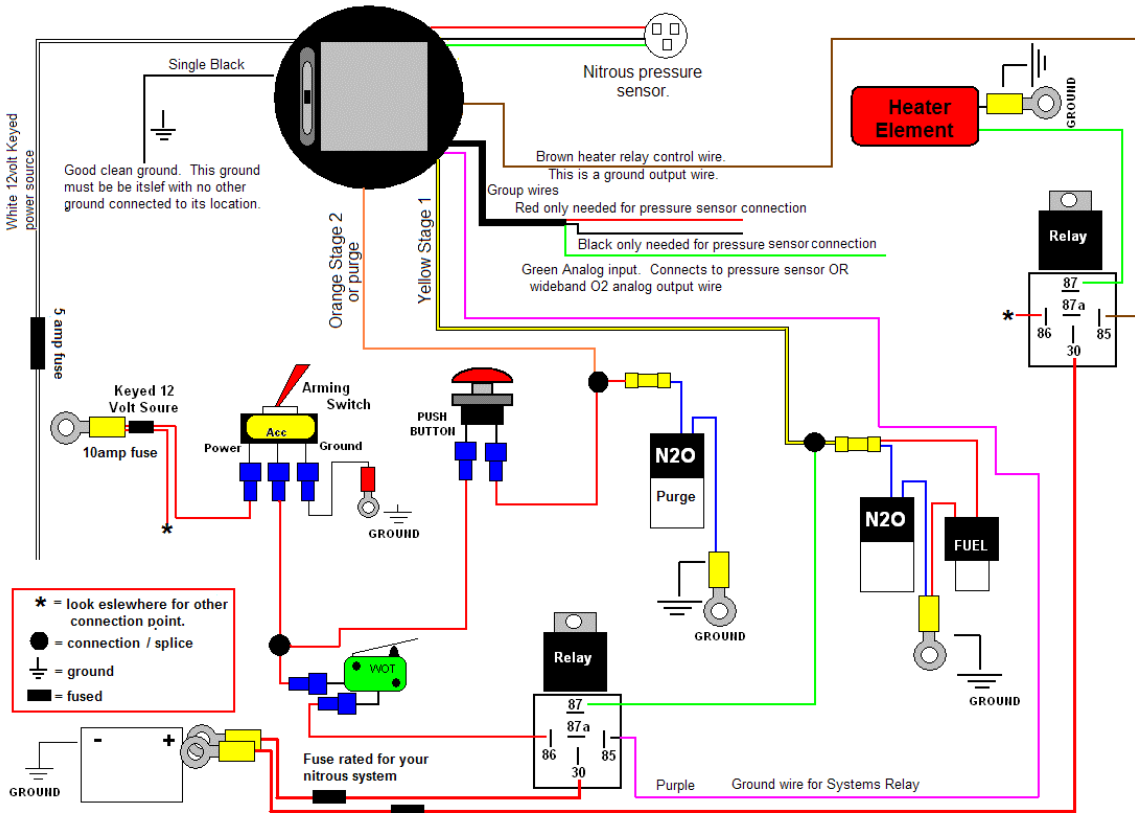

illustration -

